



CEILING
LIGHTING
AMBIENCE



METAL CEILING S7

RAIL CHANNEL SYSTEM

PRODUCT DATA SHEET

METAL CEILING S7

RAIL CHANNEL SYSTEM

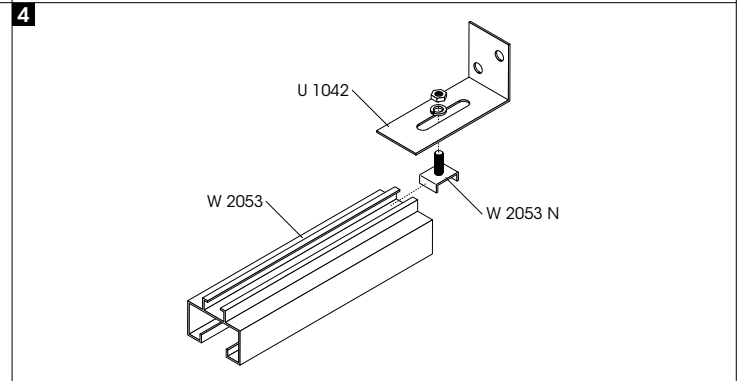
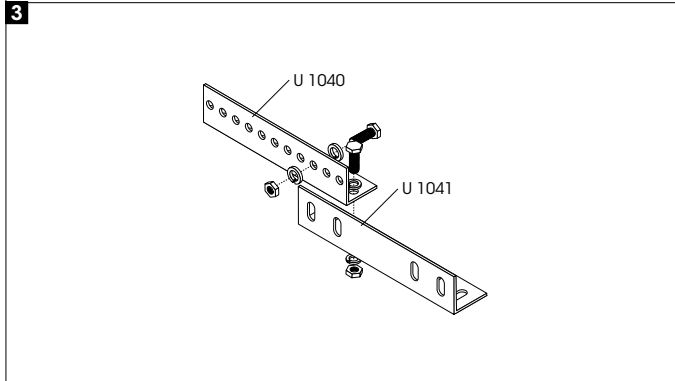
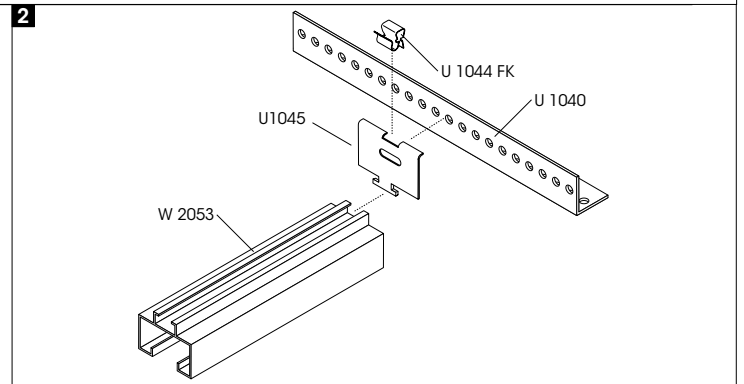
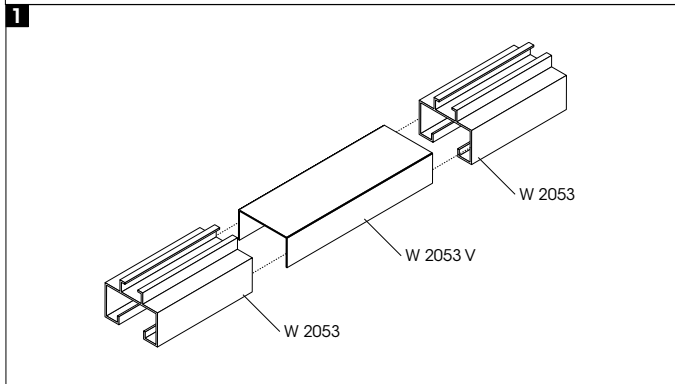
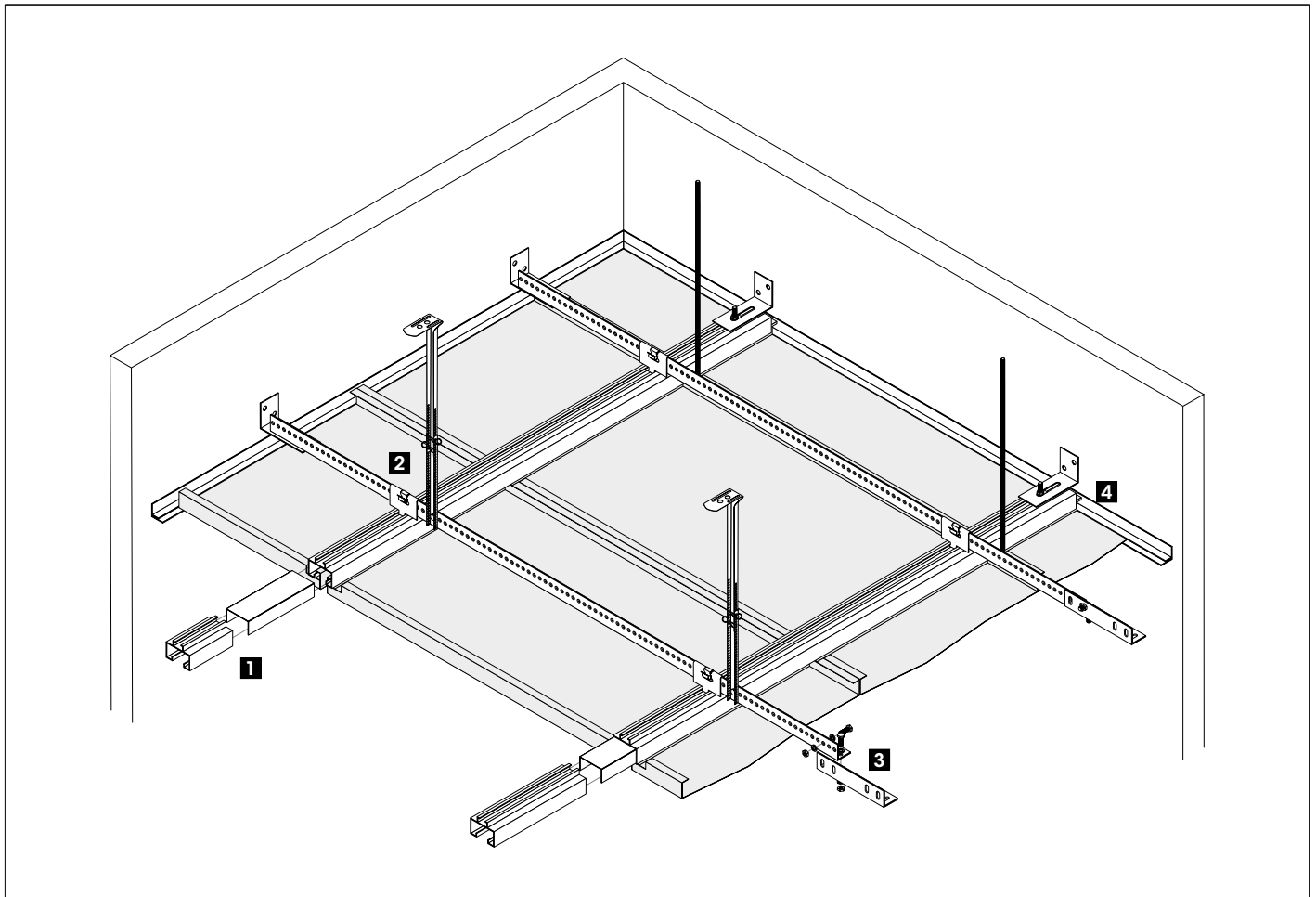

RAIL CHANNEL SYSTEM

The modern durlum S7 metal ceiling offers a host of applications. The rail channel system is especially suited for sales areas, transport buildings or other applications requiring ceilings with integrated sign-posting. Its solid design also makes it suitable for sports halls or other areas subject to pull and impact forces. S7 is distinguished by flexible design options in terms of materials, surfaces and design. With its symmetrical panels, the S7 hook-in system with a front-sided joint of 13/32" [10mm] standard allows for easy planning and is easy to demount and without requiring tools. The integration of partitions is possible upon request. Depending on your requirements, the system can also be supplied sound-proof or sound-absorbing or printed with graphics. The metal ceiling contributes directly to Green Building / LEED certification. durlum S7 metal ceilings fall under the general Master Format section 09 50 00 ceilings. When the S7 ceiling panels are supplied perforated and with sound absorption materials, they could be more specifically listed under section 09 51 33 Acoustical Metal Pan Ceilings.

SURFACE

Galvanized steel, aluminium, stainless steel. The thickness of the material depends on structural requirements. The galvanized steel and aluminium can be powder-coated in white matt [similar to RAL 9016] or according to customer specifications. The coating thickness is approx. 60µm. The aluminium can also be supplied coil anodized or mirror polished. Stainless steel rectangular metal panels are available brushed or mirror polished. The powder-coated blanks can also be printed with graphics and textures of your choice.

SYSTEM DETAILS

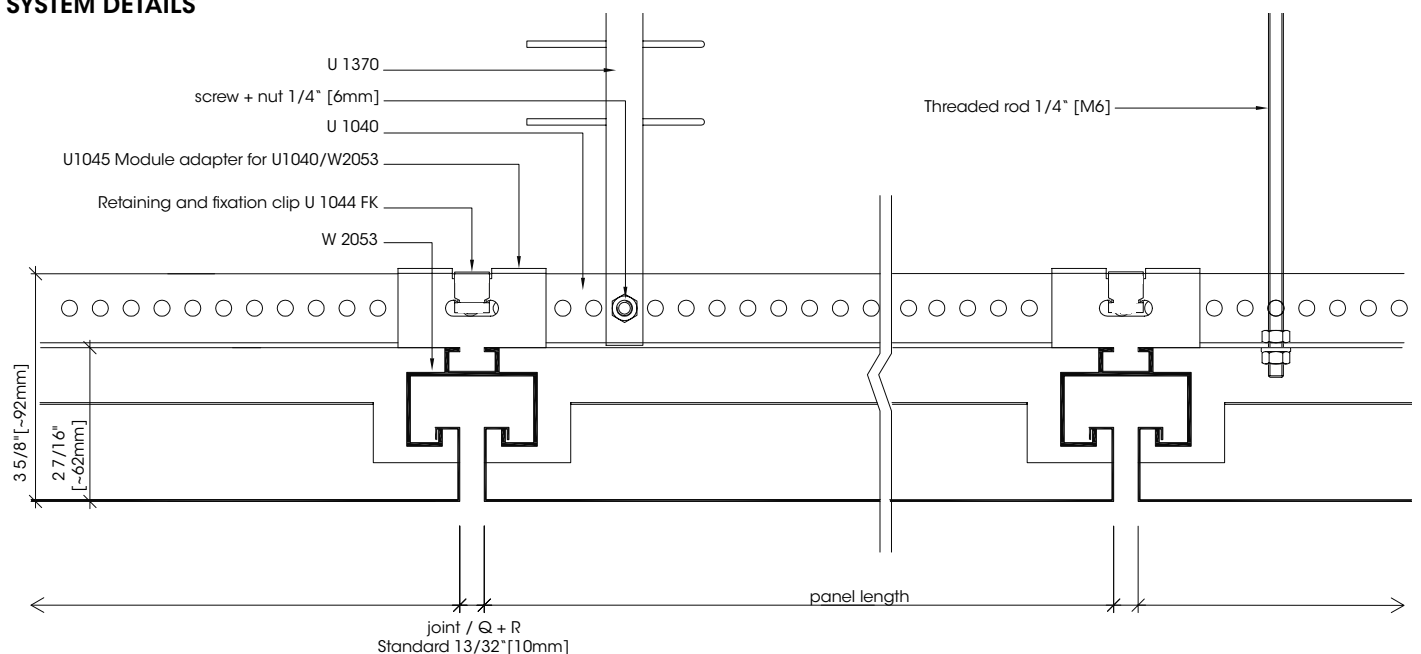

DIMENSIONS

Panel size

Length: ≤ 11'-6" [≤ 3500mm]

Width: ≤ 4'-3" [≤ 1300mm]

Recommended surface area: ≤ 32ft² [≤ 3.0m²]

PERFORATION AND ACOUSTICS

Metal panels are available perforated with black acoustic fleece or non-perforated. durlum offers RG L15 perforation [NRC=approx. 0.7] and RG 08 "Pico-Point" Microperforation [NRC=approx. 0.6] as standard. For other available perforations please see www.durlum.us.

FIRE PERFORMANCE

In accordance with ASTM E84 Flame Spread Index for steel is 25 or less and Smoke Developed Index for steel is 50 or less.

GREEN BUILDING

durlum metal panels contribute directly to LEED and other GREEN BUILDING certifications. Typically applicable credits under LEED v4:

- Recycled Content – post- & pre-consumer info
- VOC Emissions – conformity with VOC requirements
- Acoustic Performance – sound absorption with acoustic fleece
- Environmental Product Declaration – available

No substances as outlined in the US Living Building v.3 Red List are internationally used.

Learn more: greenbuilding@durlum.us

PERFORATIONS

Micro Perforation RG-L08 "Pico Point"

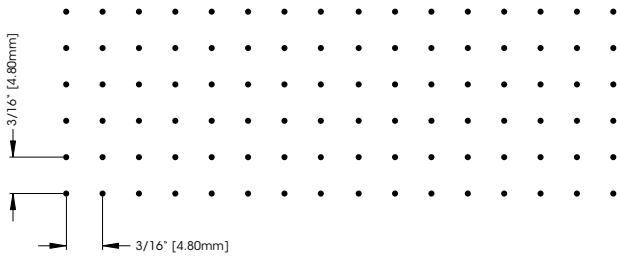

Hole diameter: $1/32''$ [0.8mm]
 Open area: 2.18%
 Max. width of perforation: $4'-2\ 1/16''$ [1272mm]
 Max. plate width: $4'-7\ 1/8''$ [1400mm]

Standard Perforation RG-L15

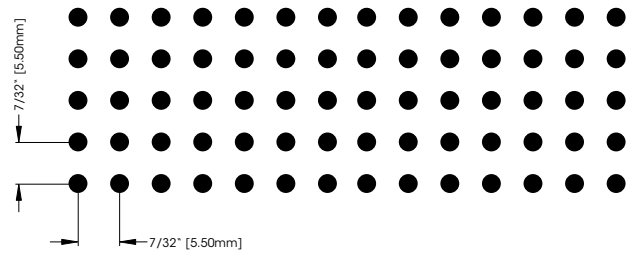

Hole diameter: $3/32''$ [2.5mm]
 Open area: 16.20%
 Max. width of perforation: $4'-8\ 3/4''$ [1441mm]
 Max. plate width: $4'-7\ 1/8''$ [1400mm]

STANDARD PANEL

Standard [Notch BB]

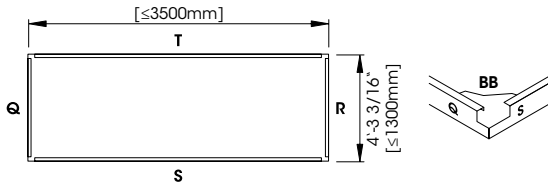

Alternative [Notch B]

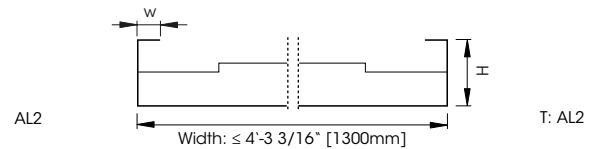
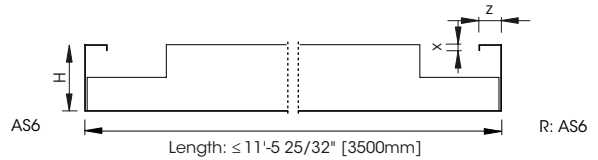
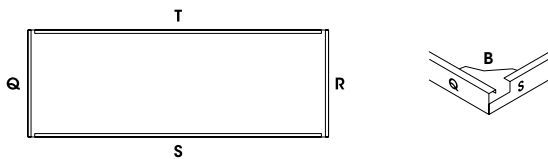

AS 6: H= $1\ 3/16''$ [30mm] | z= $13/32''$ [10mm] | x= $3/16''$ [5mm]
 AL 2: H= $1\ 3/16''-2\ 3/8''$ [30-60mm] | w= $15/32''$ [12mm]

PERIMETER DETAILS

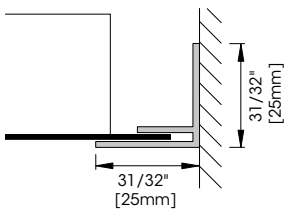

F 025 wall angle
 For perimeter panels,
 to be cut on site

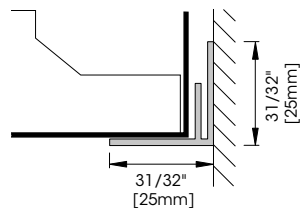

F 025 wall angle
 For lay-on perimeter
 panels

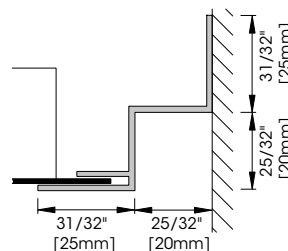

F 2025 shadow gap wall angle
 For perimeter panels,
 to be cut on site

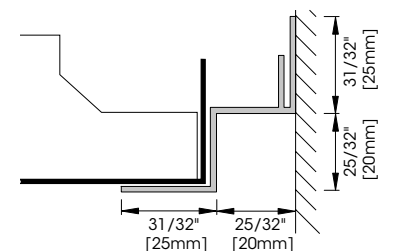

F 2025 shadow gap wall angle
 For lay-on perimeter
 panels

RAIL CHANNEL SYSTEM

INSTALLATION

The rectangular metal panels are hooked form-fitting and tension free into a special substructure, the parts of which must be approved by the manufacturer of the rectangular metal panels. Demounting without requiring tools is assured.

The substructure consists of U 1040 form-punched, L-shaped primary carriers acting as cross bracing [primary profile]. They are suspended rigidly from the bare ceiling with nonius suspension elements or threaded rods using officially approved anchors. The primary profiles are to be connected together at the longitudinal joints using U 1041 connectors. The primary profiles are joined to the walls using the wall bracket U 1042. The spacing of primary carrying profiles is determined by the applicable market standards and project requirements (static loads) and is to be determined and checked by the contractor. Ensure horizontal and flush alignment. The primary profiles U 1040 are connected to the secondary profiles W 2053 using W 2053 N slot keys. Alternatively, the secondary profiles can be suspended directly without a primary profile by using nonius suspension elements. The secondary profiles are connected together at the longitudinal joint using connector W 2053 V. U 1042 is used for joining the secondary profiles to the wall. The spacing of the secondary profiles is to be adjusted precisely to the length of the rectangular metal panels to ensure that the panels are positioned tension free in the system. Ensure horizontal and flush alignment.

The rectangular metal panels can be joined to the wall using the following wall bracket profiles:
Perimeter trim F 025
Perimeter trim F 2025

Please note

Installation must be carried out by qualified and trained staff according to the instructions for installation. These are available as download at www.durlum.us.

TECHNICAL STANDARDS

The parts comply with DIN EN 13964 as well as ASTM C635 and ASTM E1264.

Production complies with the TAIM and CISCA guidelines and the durlum works standards and is quality controlled by the TÜV according to ISO 9001:2008 and ISO 14001:2004.

CLEANING

As standard, durlum ceiling panels are made with an electrostatic polyester powder coating, thus providing them with a long-term finish. The powder-coated surface should always be cleaned wearing clean gloves. First clean it with a soft, dry cloth. If dirt cannot be removed by this procedure, the cloth can also be moistened, with the addition of a pH-neutral cleaner [household detergent], if necessary. Contact of the powder coating with both alkaline and acid substances must be avoided. Metallic powder coatings show a particularly sensitive reaction. Due to the risk of a change in hue or effect, for metallic coatings a suitability test must be performed.

More information: durlum.us

MANUFACTURER



durlum GmbH
An der Wiese 5
79650 Schopfheim
Germany

P: +49.7622.3905.0
E: info@durlum.com
I: durlum.com

CONTACT



durlum USA LLC
251 Little Falls Drive
Wilmington
Delaware 19808
USA

P: 1.800.204.3830
E: infoUSA@durlum.com
I: durlum.us